

Development of Low Cost and Portable Analog Active Noise Control System for Reduction of Low Frequency Noise

T. Venkata Ratnam^{1*}, P. Seetharamaiah², P. V. G. D. Prasad Reddy³ and G. V. Satyanarayana⁴

¹Research Scholar, CS & SE Dept., College of Engineering (A), Andhra University, Visakhapatnam, Andhra Pradesh, India. Email: ratnamtv2k6@gmail.com

²Professor Emeritus, CS & SE Dept., College of Engineering (A), Andhra University, Visakhapatnam, Andhra Pradesh, India.

³Professor & Head of the Dept., CS & SE Dept., College of Engineering (A), Andhra University, Visakhapatnam, Andhra Pradesh, India.

⁴Professor, Raghu Institute of Technology & Sciences, Visakhapatnam, Andhra Pradesh, India.

*Corresponding Author

Abstract: This paper presents the performance of the portable analog active noise control system developed in this research by conducting experiments for reducing tonal (periodic) noise and broadband noise generated by a ventilation fan. The amount of noise reduction obtained is 3 - 15 dB for one-third octave band tonal frequencies between 63 Hz to 1000 Hz. The broadband noise reduction achieved is 6 - 9 dB for two different fan noise sources. The results showed that the analog ANC system developed is compact and moderately working on reducing low frequency noise sources in air handling acoustic ducts. The several reasons for a low noise reduction performance using analog ANC system are discussed in this paper.

Keywords: Active noise control, Analog ANC system, Low frequency noise reduction.

I. INTRODUCTION

The problem of low frequency acoustic noise in the industrial environment has grown with increase of industrial equipment such as engines, fans, blowers, transformers, and air conditioning ventilation ducts etc [1 - 4]. Current traditional passive noise control techniques either affects low frequency noise or incur extreme high costs (e.g., passive silencers and barriers), making these techniques ineffective in reducing low frequency noise in ventilation ducts [5 - 7]. Active Noise Control (ANC) is potential low frequency noise mitigation technique in view of the falling costs of electronic components as well as incurring minimal obstruction when installed on ventilation ducts [8]. The first generation embedded Active Noise Control (ANC) Systems are Analog Control Systems and used a simple “*delay and invert*” approach. They showed some promising noise reduction, but their effectiveness is limited due to the rapid changes in the environment. On the other hand, analog systems are often faster and less expensive.

Analog systems are dealt with in terms of automatic control theory, where the external noise is viewed as a disturbance source to be minimised.

The Analog ANC System is designed and implemented for reducing tonal noise and ventilation fan noise sources. The tonal noise is generated at different octave band frequencies with the help of a function generator and the output is connected to a loudspeaker to produce the tonal noise. Another loudspeaker is used as an actuator to generate anti-noise by developed analog ANC system by simple delay and invert approach.

II. LITERATURE REVIEW

Most of the analog ANC devices have been built in earmuff or supra-aural headset configurations, an earplug example, has been prototyped [9]. The recent data published in the open literature on ANC-based applications from analog to digital are reported [10, 11]. Some researchers experimented and demonstrated feasibility of active noise canceling using analogue chips for real world applications [12 - 14].

To achieve maximal noise cancellation, physical mixing of the anti noise signal with the offending noise signal is critical, so correct geometric placement of transducer components, as well as accurate timing in the generation of the anti-noise, are fundamental to the success of an ANC device [15]. In an ideal sense, because ANC circuitry adds two out-of-phase noises that are of equal amplitude, the resultant amplitude should be zero and the effect one of complete cancellation. But this would require propagation with zero time delay between the various system, transducers and the listener, which is physically impossible with the loudspeaker, microphone, and listener’s position all located at different points in space.

Due to the phase shifts that can be attributed to these transducer location differences, as well as the possibility of throughput

delays in signal processing, establishing the correct phase relationship of cancellation signal and noise becomes more difficult as the bandwidth of the noise increases; therefore, ANC has typically been most effective against low-frequency noise. For example, with contemporary analog ANC devices, maximal attenuation values of about 20 dB are typically found to be in a range from about 100 to 250 Hz, and there will be no attenuation above the frequency of 1000 Hz [16].

Noise reduction (typically 3 to 6 dB, but in some cases more) occurs in the midrange frequencies (about 1000 to 3000 Hz) with some analog ANC devices [17]. This can occur when the overall acoustic gain is close to unity, and the phase relationship is close to the in-phase condition, producing addition rather than cancellation. In the midrange, due to the transducer and headset characteristics, there may be a rapid variation in phase with frequency that can result in wave addition. Midrange enhancement in some devices has manifested when a loss of earmuff cushion seal occurs, resulting in instabilities in the cancellation system [17]. However, it has been demonstrated that enhancement can be minimized by appropriate electro acoustic design [18].

Amar Bose [19], provides a classical example of a closed loop system for active noise cancellation, which produces a noise reduction of 20 dB. The headphone / ear-cavity system is treated as a physical plant to be controlled, and the open loop gain is increased as much as possible without compromising on the stability of the closed loop system. Bose’s circuit consists of a lead-lag compensator which achieves this requirement.

III. DESIGN AND DEVELOPMENT OF ANALOG ANC SYSTEM

A generic Analog Active Noise Control System is designed and developed for reducing low frequency noise generated by a noise source. The functional block diagram depicting the components of a typical analog ANC system for one dimensional acoustic duct is shown in Fig. 1. It is a closed-loop analog ANC System that receives input from a reference microphone that detects the input noise produced by a noise source in the one dimensional acoustic duct.

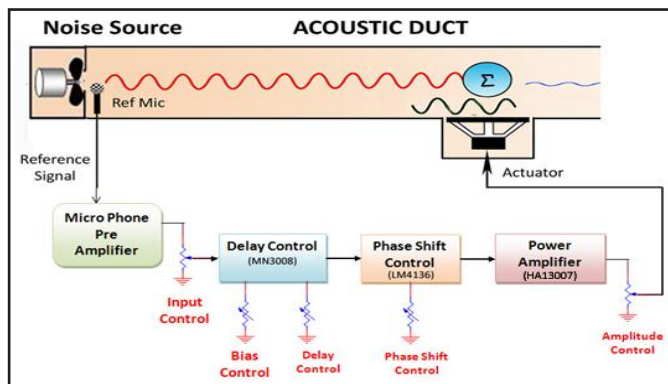

Fig. 1: Components of Typical Analog ANC System

The input noise signal is then fed back through a pre-amplifier

to increase the strength of the input noise signal as the output of reference microphone is weak signal. The amplified noise signal is fed to the controller, which contains delay and phase shift controller. The delay controller (MN 3008) makes a suitable amount of delay to the input noise signal and fed to the phase shift controller. The phase shift controller (LM 4136) inverts the input noise signal to 180 degrees out of phase noise and is fed to the loudspeaker through a power amplifier to obtain a required output noise in the acoustic duct. Then the secondary noise generated by loudspeaker through the power amplifier (HA 13007) is acoustically combined in the duct with the primary noise and thereby reduces noise due to destructive interference.

The various components of typical analog ANC system in the form of circuit diagram are shown in Fig. 2.

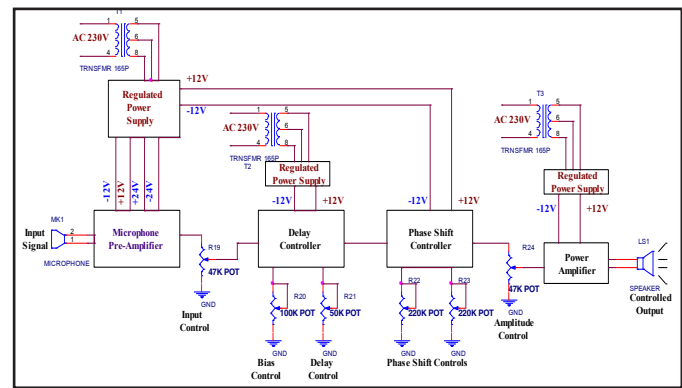

Fig. 2: Circuit Diagram of Analog ANC System

The related circuit diagrams like power supply and pre-amplifier circuit diagrams are shown in Fig. 3(a) & Fig. 3(b).

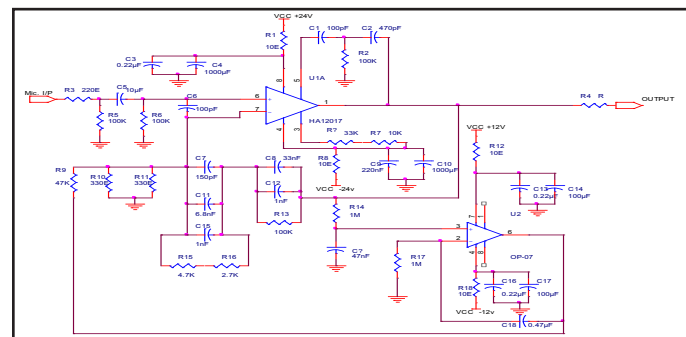

Fig. 3(a): Pre-Amplifier Circuit

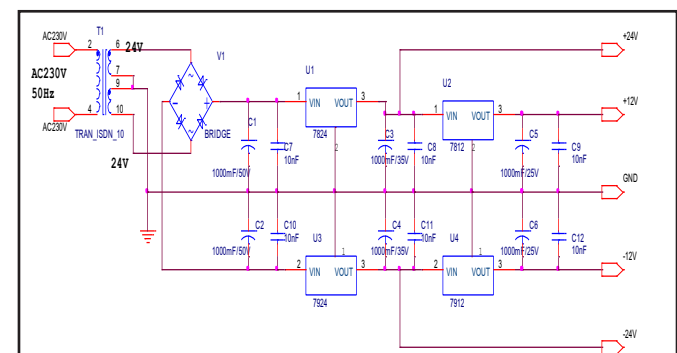

Fig. 3(b): Power Supply Circuit

The final prototype of analog ANC system is housed in a box as shown in Fig. 4(a) and Fig. 4(b).



Fig. 4(a): Prototype of Analog ANC System

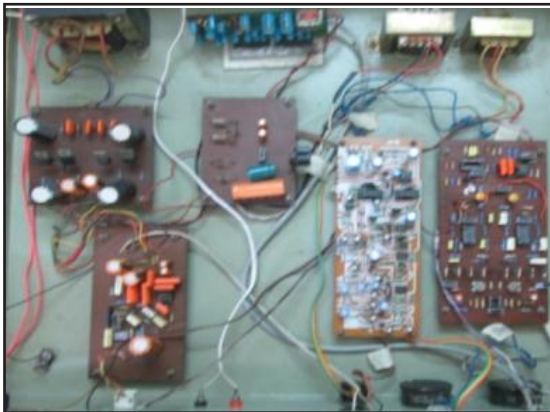

Fig. 4(b): Prototype of Analog ANC System

IV. ANALOG ANC SYSTEM FOR TONAL NOISE REDUCTION

The experimental setup of one dimensional acoustic duct was built in the Embedded Systems Laboratory of Department of Computer Science & Systems Engineering (CS & SE) at Andhra University College of Engineering (A) for testing analog ANC system. The experimental test setup consists of a rectangular wooden acoustic duct and an Iron acoustic duct. Further, a modular and detachable two cubical boxes were fabricated for housing noise sources (a loudspeaker and a ventilation fan) for generating tonal and broadband / fan noise respectively. The objective of this experiment is to reduce low frequency noise generated by the primary noise source fitted at one end of the duct and the noise level is measured at the other end of the duct using analog ANC system.

A. Experimental Setup for Tonal Noise Reduction

The experimental setup of tonal noise reduction for 1/3 octave frequencies using analog ANC system consists of a primary noise source (loudspeaker) attached to one end of the duct. It is driven by a function generator through an amplifier to generate tonal noise of 1/3 octave frequencies ranging from 63 Hz to 1000 Hz. The reference microphone at one end of duct senses

the tonal noise generated by the loudspeaker as input signal and then fed to the analog ANC controller, which contains delay and the phase shift controller. The analog ANC controller, converts input signal to anti-noise and fed to the loudspeaker through a power amplifier to obtain a required output (secondary) noise in the acoustic duct. Then the secondary noise generated by loud speaker is acoustically combined in the duct with the primary noise and thereby reduces noise due to destructive interference. The functional diagram of experimental setup of tonal noise generated by a loudspeaker in an acoustic wooden duct is shown in Fig. 5. The corresponding experimental setup in laboratory is shown in Fig. 6.

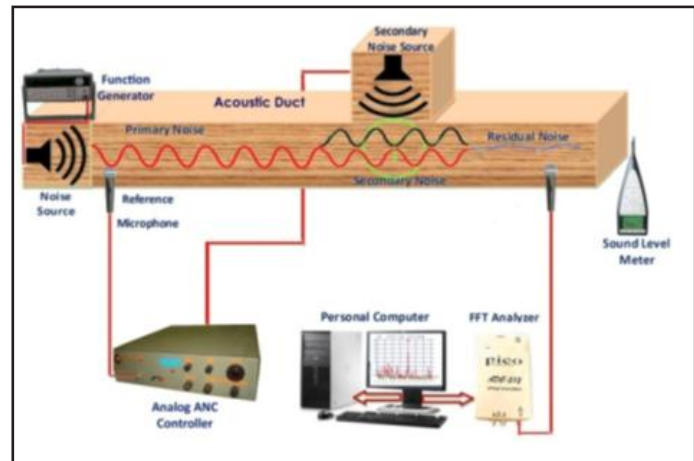

Fig. 5: Functional Diagram for Testing Analog ANCS with Speaker



Fig. 6: Experimental Setup for Testing Analog ANCS with Speaker

B. Operating Procedure

The experimental setup consists of a function generator for generating octave band frequencies and loudspeaker to produce source noise. The loudspeaker is placed at the left side of the duct and is connected to a function generator to produce source noise. After placing the noise source unit, acoustic duct, Analog Active Noise Controller, Ref. Mic., and anti-noise speaker as per the experimental setup shown in the Fig. 6, the interconnections

were made and varied the controls on the front panel of analog controller unit.

By trial and error variation of the control knob, phase shift knob, bias control knob and delay knobs are adjusted until the maximum reduction of noise is achieved.

C. Brief Details of the Analog ANC System

The following are the brief details of the analog ANC system using Analog Controller for an acoustic duct.

Physical System: Acoustic Duct: 10” x 12” x 12”

Noise Source: Ventilation Fan: RPM: 2250, Blades: 4, BPF = 150Hz

Sensors: Ref. Mic.: Sensitivity: 2.5 mV/Pa at 1kHz

Frequency Response: 50-15000 Hz

Actuator: Woofer: 8 Ohms, 40Watts, 20Hz- 1kHz

Noise Controller Unit:

1. Analog Controller ANC System,
 - 1- Ref. Mic., 1 Anti-noise control output,
 - Manual feedforward control
2. +5V @ 2A and +12V @1A Power Supplies
3. Power Amplifier for Output Control

D. Results for Analog System for Tonal Noise Reduction

The experimental results of Analog ANC system for reduction of tonal noise levels are compared using a bar chart as shown in Fig. 7. The grey color bars show that when Analog ANC OFF, i.e., without switching on the Analog ANC System, the source noise directly reaches the receiver microphone. The black color bars show that when the Analog ANC System was ON, i.e., the source noise is reduced by switching on the Analog ANC System.

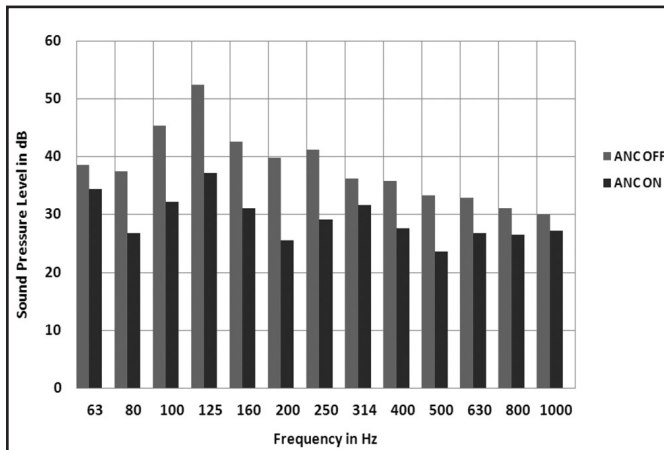

Fig. 7: Tonal Noise Levels Using Analog ANC (OFF) and (ON)

It can be clearly seen from the Fig. 7 that the Analog ANC System is functioning and achieving an appreciable tonal noise reduction of 3 - 15 dB using developed Analog ANC System. The corresponding experimental results of tonal noise control using Analog ANC system are given in Table I.

TABLE I: RESULTS OF TONAL NOISE REDUCTION USING ANALOG ANC SYSTEM

| Octave Frequencies in Hz | 63 | 80 | 100 | 125 | 160 | 200 | 250 | 314 | 400 | 500 | 630 | 800 | 1000 |
|--------------------------|------|------|------|------|------|------|------|------|------|------|------|------|------|
| Amplitude in dB ANC OFF | 38.5 | 37.4 | 45.3 | 52.4 | 42.5 | 39.7 | 41.1 | 36.2 | 35.8 | 33.3 | 32.8 | 31.1 | 30.0 |
| Amplitude in dB ANC ON | 34.3 | 26.7 | 32.1 | 37.2 | 31.1 | 25.5 | 29.1 | 31.6 | 27.6 | 23.6 | 26.7 | 26.5 | 27.1 |
| Noise Reduction in dB | 4.2 | 10.7 | 13.2 | 15.2 | 11.4 | 14.2 | 12.0 | 4.6 | 8.2 | 9.7 | 6.1 | 4.6 | 2.9 |

V. ANALOG ANC SYSTEM FOR VENTILATION FAN NOISE REDUCTION

The experimental setup of one dimensional acoustic wooden duct is also used for reducing Ventilation Fan noise reduction with the developed Analog ANC System. The objective of this experiment is to reduce Blade Pass Frequency (BPF) noise, which is a dominant source of noise generated by the ventilation fan. The developed Analog ANC System is tested for its noise reduction performance with two different fans (noise sources) attached independently with two different rectangular acoustic ducts, namely, wooden acoustic duct and an Iron acoustic duct. These Fans are attached at one end of the duct and measured the blade frequency noise levels at the other end of the ducts. The experimental details are presented in the succeeding sections.

A. Wooden Acoustic Duct (Experiment 1)

The functional block diagram of experimental setup for testing Analog ANC System with a ventilation fan in a rectangular one dimensional acoustic wooden duct is shown in Fig. 8. This experiment is conducted for testing Analog ANC System to reduce the Blade Pass Frequency (BPF) noise generated by the fan.

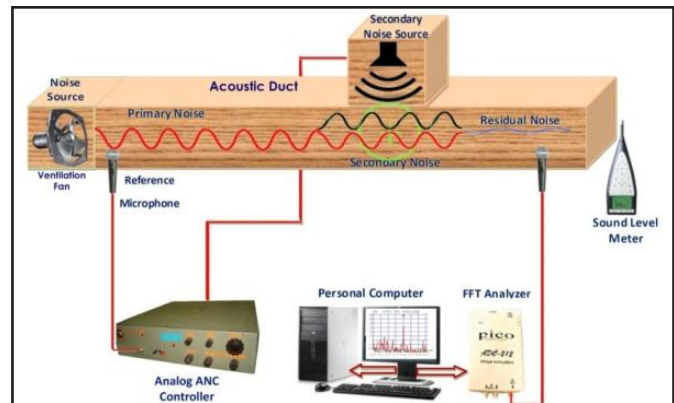

Fig. 8: Functional Diagram for Testing Analog ANCS with Fan

The Experimental setup consists of a ventilation fan as a primary noise source for generating BPF noise in a wooden acoustic duct. The ventilation fan is placed at the left side of the acoustic duct. After attaching the Fan unit to the duct, Analog Active Noise Controller, Ref. Mic., and Anti-noise speaker are connected as per the experimental setup shown in the Fig. 9. The controls on the front panel of analog controller unit are varied as explained in the previous section to achieve the maximum reduction of blade pass frequency noise of a fan.



Fig. 9: Experimental Setup for Testing Analog ANCS with Fan

B. Results of Analog ANCS for Wooden Duct

The experiment conducted for testing the complete Analog ANC System configured for reducing Fan noise in wooden acoustic duct. The ventilation fan is attached to the left end of the acoustic wooden duct is measured with a microphone placed at the other end of the wooden duct using analog ANC system. The Blade Pass Frequency (BPF) noise levels of the fan at 153 Hz is measured at the right side of the wooden duct, while analog ANC system OFF and Analog ANC System ON. The corresponding experimental results without and with Analog ANC controller are plotted as shown in Fig. 10.

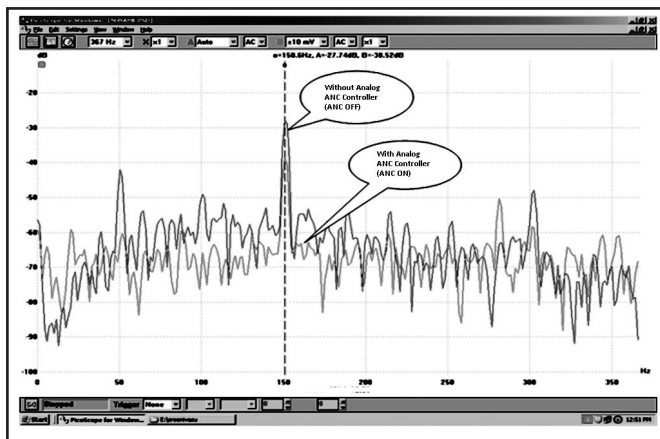

Fig. 10: Noise Levels of Fan Using Analog ANC OFF and ANC ON

The corresponding noise levels are tabulated in Table II. The results showed an appreciable reduction of 5.7 dB using Analog ANC System with a minimum time delay of 40.96 ms.

TABLE II: RESULTS OF BROADBAND / FAN NOISE REDUCTION USING ANALOG ANC SYSTEM

| Blade Pass Frequency (BPF) of Fan | Input Noise in dB | Output Noise in dB | Residual Noise in dB | Delay in ms |
|-----------------------------------|-------------------|--------------------|----------------------|-------------|
| 153 Hz | 87.3 | 82.6 | 4.7 | 40.46 |

C. Iron Acoustic Duct (Experiment 2)

The second experimental setup for testing Analog ANC System for reducing Fan noise in a rectangular one dimensional acoustic Iron duct is shown in Fig. 11. The Noise source is a ventilation fan with Blade Pass Frequency of 93 Hz.

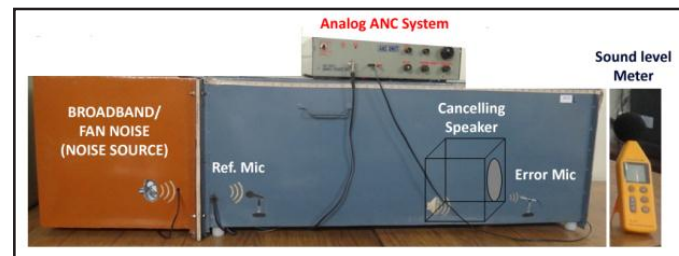

Fig. 11: Experimental Setup for Analog ANCS with Fan (Iron duct)

The front view of the Analog ANC System is shown in Fig. 12.

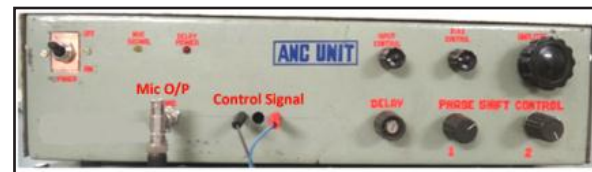

Fig. 12: Front View of the Analog ANC System

D. Brief Details of the Analog ANC System for Iron Duct

The following are the brief details of the ANC System using Analog Controller for an acoustic Iron duct.

Physical System: Acoustic IRON Duct: 50" x 18" x 18"

Noise Source: Exhaust Fan: 1400 RPM, Blades: 4, BPF = 93 Hz

Sensors: Ref. Mic. Sensitivity: 2.5 mV/Pa at 1 kHz
Frequency Response: 50-15000 Hz

Actuator: Woofer: 8 Ohms, 40 Watts, 80 Hz- 1 kHz

Noise Controller Unit:

1. Analog Controller ANC System
 - 1 - Ref. Mic., 1 Anti-noise control output, Manual feedforward control

2. +5V @ 2A and +12V @1A Power Supplies
3. Power Amplifier for Output Control

E. Results of Analog ANC System for Iron Duct

The experiment conducted for testing the complete Analog ANC System configured for reducing real-time Fan noise in an acoustic Iron duct. The ventilation fan is attached to the left end of the Iron duct and the Sound Pressure Levels (SPL) of blade pass frequency (93 Hz) noise of the fan is measured at the right side end of the acoustic duct. The SPL amplitudes while analog ANC System switched off (ANC OFF) and with Analog ANC System switched on (ANC ON) are given in Table III. The results showed an appreciable reduction of 8.42 dB using analog ANC system for acoustic duct.

TABLE III: RESULTS OF FAN NOISE LEVELS USING ANALOG ANCS (IRON DUCT)

| Blade Pass Frequency (BPF) of Fan | Input Noise in dB | Output Noise in dB | Residual Noise in dB |
|-----------------------------------|-------------------|--------------------|----------------------|
| 93 Hz | -15.24 | -23.66 | 8.42 |

The corresponding acoustic noise data is measured from reference and error microphones are plotted while analog ANC controller OFF and analog ANC System ON as shown in Fig. 13 and Fig. 14 respectively. The *black color* represents ref. mic signal and *grey color* indicates error mic signal. When Analog ANC System is OFF, i.e., analog ANC System switched off, the source noise directly measured with the error microphone and when analog ANC System is switched on, i.e., the source noise is measured after controlling through the analog ANC System.

Ref. Mic. & Error Mic. Frequency Domain Signals Before ANC Freq.:92.14Hz, CH-A(BLUE) = -25.16dB, CH-B(RED) = -15.24dB

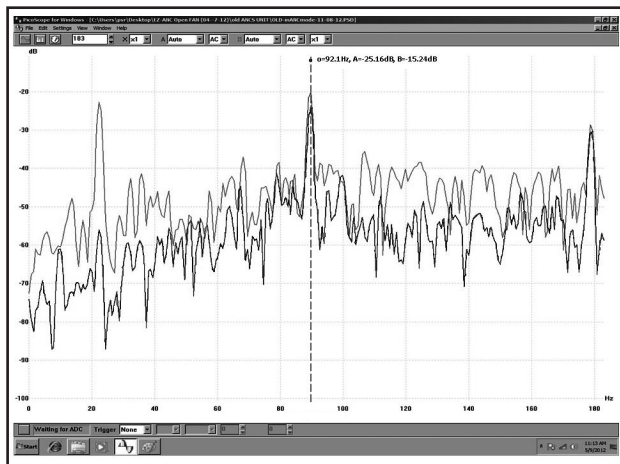

Fig. 13: Fan Noise Levels Using Analog ANC OFF (Iron Duct)

Ref. Mic. & Error Mic. Frequency Domain Signals After ANC Freq.:92.14Hz, CH-A(BLUE) = -25.16dB, CH-B(RED) = -23.66dB

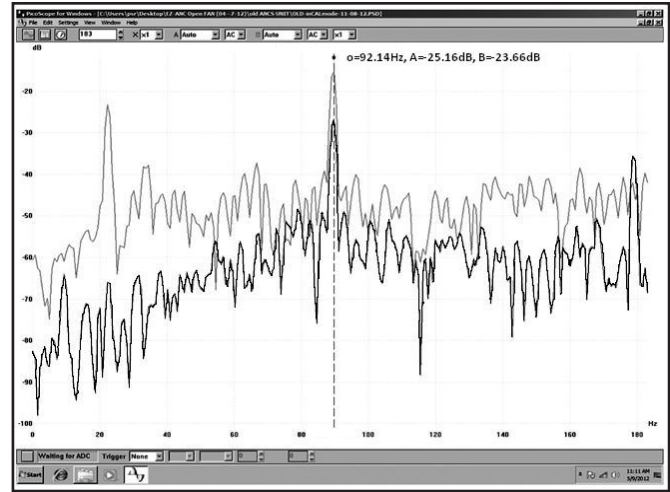

Fig. 14: Fan Noise Levels Using Analog ANC ON (Iron Duct)

VI. RESULTS AND DISCUSSION

The development of low cost and portable analog active noise control was fairly successful in this research work. After completion, the analog ANC for reduction of tonal noise and broadband noise in an acoustic duct worked fairly satisfactorily, and were able to cancel blade pass frequency noise of two different types of ventilation fans attached to two different types of air handling acoustic ducts, namely, wooden and Iron acoustic ducts. The analog ANC system is tested by observing the noise reduction performance of various sources of noise generated such as tonal noise at octave frequencies and broadband noise of two different types of ventilation fans.

The noise reduction achieved for one-third octave tonal frequencies is 3 - 15 dB with this analog ANC system in the acoustic duct. The broadband noise reduction of nearly 6 - 9 dB for two different fan noise sources. There are several reasons for this kind of a low noise reduction performance using analog ANC system. The reasons for noise reduction performance of the system are given below:

- i) There will be an acoustic propagation delay occurs between the disturbing noise reaching the microphones placed near the source noise and at the receiver end of the duct. The anti-noise signal generated by the loudspeaker is not perfectly inverted, but is also out of phase. The difference in phase delay leads to increase with the frequency of the disturbing noise, tends to performance degradation.
- ii) The reference microphone is placed at a point close to the source noise. There is a chance that the source noise propagates in the duct is detected by the reference microphone, and that reaching the receiver end of the duct are different. This will happen if the position of the source keeps changing. Further, the dynamics of the duct would alter the noise reaching the receiver end of the duct vis-a-vis the noise reaching the reference microphone. The positioning of reference and error microphones would

also lead to a mismatch between the noise and anti-noise signals.

- iii) The system depends upon the tuning of microphone pre-amp gain manually, in order to achieve required amount of noise reduction. The tuning of microphone pre-amp gain lead to mismatch with the source noise level may lead to a degradation in the performance.

VII. CONCLUSION

The main contribution of this research is a design and development of a portable analog ANC system that can reduce low frequency tonal / fan noise in an air handling acoustic duct with low cost, compact and with a considerable amount of noise reduction.

One major disadvantage of this analog system is that it does not allow the freedom of designing filters to achieve an optimality criterion - such as least mean squares. It is limited in scope of practical issue of implementing analog domain transfer functions. Thus, the level of noise cancellation possible from analog systems is lower than what is possible from digital adaptive filters.

The present analog ANC system requires further tuning in order to achieve anti-noise signal that exactly matches the source noise level with the same amplitude. However, this analog ANC system demonstrated the analog active noise cancellation with reasonable noise reduction in a low cost and compact in size compared to traditional passive noise control approaches.

ANC today is a realizable technology and not black magic. It has been successfully applied to a variety of applications and will see a significant wide application in the coming years.

REFERENCES

- [1] S. M. Kuo, and D. R. Morgan, "Active noise control: A tutorial review," *Pro. IEEE*, vol. 87, no. 6, pp. 943-973, 1999.
- [2] S. M. Kuo, K. Kuo, and W. S. Gan, "Active noise control: Open problems and challenges," *Int. Conf. Green Circuits Syst.*, pp. 164-169, 2010.
- [3] N. V. George, and G. Panda, "Advances in active noise control: A survey, with emphasis on recent nonlinear techniques," *Signal Processing*, vol. 93, no. 2, pp. 363-377, 2013.
- [4] Y. Kajikawa, W. S. Gan, and S. M. Kuo, "Recent applications and challenges on active noise control," In *Proceedings of the 8th International Symposium on Image and Signal Processing and Analysis (ISPA '13)*, Trieste, Italy, September 2013.
- [5] B. Somek, M. Dadi, and M. Maleti, "Active noise control in ducts," *Automatika*, vol. 42, no. 1-2, pp. 5-12, 2001.
- [6] Y. Kobayashi, and H. Fujioka, "Inexpensive implementation of active noise control systems for one-dimensional duct with application to a ventilating system," In *Proceedings of the 13th International Congress on Sound and Vibration (ICSV '06)*, Vienna, Austria, July 2006.
- [7] M. Larsson, "Active control of noise in ventilation systems: Analysis and experiments," Blekinge Institute of Technology, Doctoral Dissertation Series No. 2011:11.
- [8] B. Lam, and W. S. Gan, "Active acoustic windows: Towards a quieter home," *IEEE Potentials*, vol. 25, no. 1, pp. 11-18, 2016.
- [9] K. Buck, and R. Franke, "Active noise cancellation in an ear plug," *Scand. Audiol.* (Suppl. 4, XXI Nordic Congress of Military, Medicine), 159, 1990.
- [10] R. Schirmacher, "Current status and future development of ANC systems," *Inter-Noise 2015, 44th International Congress on Noise Control Engineering*, San Francisco, CA, August 2015, Sound & Vibration, pp. 16-19, September 2016.
- [11] D. Miljković, "Active noise control: From analog to digital - last 80 years," *MIPRO 2016/CTS*, pp. 1358-1363, 2016.
- [12] J. W. Cho, and S. Y. Lee, "Active noise canceling using analog neurochip with on-chip learning capability," In *Proceedings of the 11th International Conference on Neural Information Processing Systems (NIPS'98)*, pp. 664-670, 1998.
- [13] Y. K. Choi, K. H. Ahn, and S. Y. Lee, "Effects of multiplier offsets on chip learning for analog neuro-chip," *Neural Processing Letters*, vol. 4, no.1, pp. 1-8, 1996.
- [14] T. Enomoto, T. Ishihara, and M. K. Yasumoto, "Integrated tapped MOS analogue delay line using switched-capacitor technique," *Electronics Letters*, vol. 18, no. 5, pp. 193-194, 1982.
- [15] M. Antila, K. Hakanen, and J. Kataja, "Microcontroller driven analogue filter for active noise control," *ACTIVE 2002*, ISVR, Southampton, UK, pp. 449-456, 15-17 July 2002.
- [16] K. P. Waye, "Noise and health - Effects of low frequency noise and vibrations: Environmental and occupational perspectives," pp. 243-253, December 2011. DOI: 10.1016/B978-0-444-52272-6.00245-2.
- [17] C. W. Nixon, R. L. McKinley, and J. W. Steuver, "Performance of active noise reduction headsets in noise-induced hearing loss," In A. L. Dancer, D. Henderson, R. J. Sam, and R. P. Hamernik (eds.), St. Louis, MO: Mosby Year Book, Inc., pp. 389-400, 1992.
- [18] M. C. J. Trinder, and O. Jones, "Active noise control at the car," In *Proceedings of NOISE-CON 87*, State College, PA, pp. 393-399, 8-10 June 1987.
- [19] A. Bose, Headphoning, US Patent No. 4,455,675, 1984.