

ACTIVE FILTER FOR HARMONIC REDUCTION

V.S.Baste^{1*}, R.T.Patil² and S.R.sonawane³

1 - Dept. of Electronics & Telecommunication, SIT, Lonavala

2 - TKOET, Warnanagar

3 - ACSC, Alandi, Pune

ABSTRACT

In the modern power distribution system, majority of loads draw reactive power and harmonic currents from ac source along with main power currents. These non-unity power factor linear and non-linear loads cause low efficiency of supply system, poor power-factor, destruction of other equipments due to excessive stresses and EM1 problems. Active filters have been considered an effective solution to reduce these problems. This paper presents an Active Power Filter (APF) based on simple control technique to provide reactive power and harmonics compensation for linear and non-linear single-phase loads. A voltage source inverter with carrier less hysteresis PWM current control is used to form an APF. A simple P-I (proportional-integral) dc bus voltage controller with reduced energy storage capacitor is employed in the APF

1. INTRODUCTION

Power Electronics plays an important role in the control of generated electrical energy for today's industrial applications in various industrial, commercial, residential and military environments. The control of electrical power conversion from one form to another is necessary, and is achieved through power converters. The control strategy for power converters plays an important part in the harmonic generation and the output waveform distortion. Advancement of semiconductor technology has boosted the power electronic field due to the availability of power devices such as Power MOS Field Effect Transistors (Power MOSFETs), Insulated Gate Bipolar Transistors (IGBTs) and Gate Turn Off Thyristors (GTO's) that have high power rating and good switching characteristics. These devices are widely used in the power converter circuits. However the output currents and voltages of static power converters are generally associated with low-order harmonics. The harmful effects of low-order harmonics produced by these devices can be reduced by incorporating the use of microcontroller in the control strategy of the converter circuits. This paper describes a computer-based control strategy for an ac to dc

converter using the optimization technique to reduce harmonics.

2. OVERVIEW OF HARMONICS

Harmonics are undesirable components in the sinusoidal waveform of the AC Power supply. Harmonics occur as integral multiples of the fundamental frequency.

That is, the third order harmonic will have a frequency of 3 times the fundamental frequency; 150 Hz which is 3 times the fundamental 50 Hz frequency. Harmonics affect power quality and efficiency. It is therefore necessary that Harmonics in any power system be monitored.

The harmonics can arise in three ways:

- 1) through the application of a non sinusoidal driving voltage to a circuit containing nonlinear impedance.
- 2) through the application of a sinusoidal driving voltage to a circuit containing nonlinear impedance.
- 3) through the application of a non sinusoidal driving voltage to a circuit containing linear impedance.

*Vaishali.baste@gmail

Harmonics can be rectified by using suitable methods such as filters. Using a mathematical technique known as Fast Fourier Transforms, the distorted AC waveform can be resolved into its component waveforms. Of the measured harmonics, the even harmonics (harmonics whose frequency are the fundamental frequency multiplied by even numbers such as 100Hz(2*50) or 200Hz(4*50) get cancelled out and have no effect. For the study and management of Harmonics, only the odd harmonics are considered.

The harmonic content must be reduced due to following reasons

- 1) Performance of loading device fed through inverter is affected by harmonics.
- 2) Harmonics cause additional losses.

High frequency harmonics can be reduced easily by low size filter. However, to reduce lower order harmonics, big size filter are required. Therefore, lower order harmonics must be reduced by some technique other than the filtering *i.e.* PWM.

2.1 Types of Harmonic Sources

There are two types Harmonic Sources:

- 1) Current-Source Type of Harmonic Sources
- 2) Voltage-Source Type of Harmonic Sources

2.2 Harmonic Detection Methods

There are different algorithms for harmonic detection, which lead to a large scientific debate on which part the focus should be put on, the accuracy, speed, the filter stability, easy & inexpensive implementation etc.

Frequency Domain

- 1) Discrete Fourier Transform
- 2) Fast Fourier Transform
- 3) Recursive Discrete Fourier Transform

Time Domain

- 1) Synchronous fundamental "dq-frame"
- 2) Synchronous individual harmonic "dq-frame"
- 3) Generalized integrators & variants

3. ACTIVE FILTERS

An Active Harmonic Filter is an electronic power inverter using IGBT semiconductors with various control loops to increase Power Factor and reduce harmonics by injecting a dynamic cancellation signal into the power line. The Active Harmonic Filter solution from Power Correction Systems improves the efficiency and operation of AC Motor Systems, AC Variable Frequency Drive (VFD) Systems and works well with virtually every Electrical and Electronic Device in your facility.

Active power filters were first proposed for harmonic compensation in the early 1970's, but they could not be used in real power systems because high-power high-speed switching devices were unavailable. Since then, and because of the high development of power electronics technology, much research has been done on active filters and their practical applications. The operation of an active filter is based on a continuous monitoring and conditioning of the distorted current created by the non-linear load. The same harmonic currents, but with a 180° phase shift are generated by the filter, so that harmonic components are cancelled and only fundamental component flows from the point of common coupling of the load. The increasing use of power electronics-based loads (adjustable speed drives, switch mode power supplies, etc.) to improve system efficiency and controllability is increasing the concern for harmonic distortion levels in end use facilities and on the overall power system. The application of passive tuned filters creates new system resonances which are dependent on specific system conditions. In addition, passive filters often need to be significantly overrated to account for possible harmonic absorption from the power system. Passive filter ratings must be co-ordinated with reactive power requirements of the loads and it is often difficult to design the filters to avoid leading power factor operation for some load conditions.

Active filters have the advantage of being able to compensate for harmonics without fundamental frequency reactive power concerns. This means that the rating of the active power can be less than a comparable passive filter for the same non-linear load and the active filter will not introduce system resonances that can move a harmonic problem from one frequency to another.

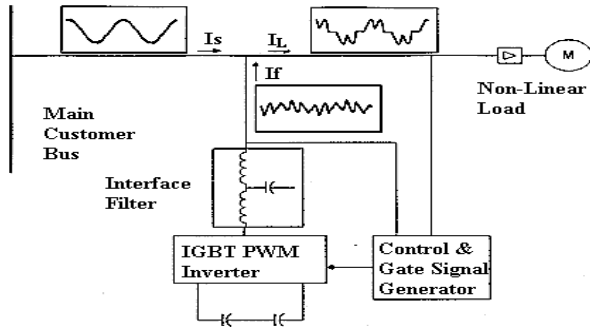

Figure 1 : Shunt Active Power Filtering

The active filter concept uses power electronics to produce harmonic current components that cancel the harmonic current components from the non-linear loads. The active filter uses power electronic switching to generate harmonic currents that cancel the harmonic currents from a non-linear load. The active filter configuration investigated in this lecture is based on a pulse-width modulated (PWM) voltage source inverter that interfaces to the system through a system interface filter as shown in Figure 1. In this configuration, the filter is connected in parallel with the load being compensated. Therefore, the configuration is often referred to as an active parallel or shunt filter.

3. RELATED WORK

Fig2. show the fundamental building block of the proposed parallel APF. It is comprised of a standard single phase voltage source MOSFET based bridge inverter with dc bus capacitor and dc boost voltage for an effective current control. A hysteresis rule based carrier less PWM current control technique is used to provide fast dynamic response of the APF

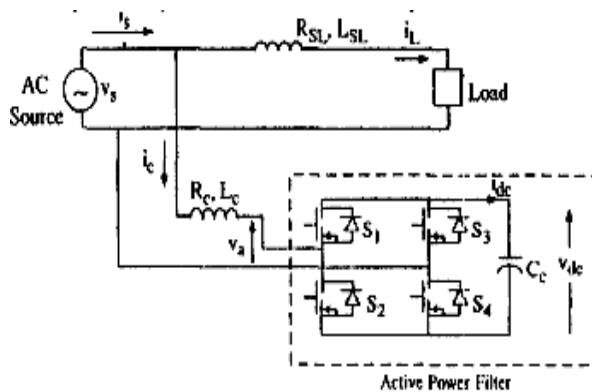

Figure 2 : Basic Circuit of the Active Power Filter

To demonstrate reactive power compensation capability of the APF, linear loads of lagging and leading power-factors are considered with the step change. Non-linear loads consisting diode rectifier with capacitive loading and solid state ac regulator with inductive loading, arc taken APF system to illustrate its capability for harmonic and reactive. power compensation The main role of the proposed APF is to eliminate harmonics and to provide reactive power requirement of the load locally so that ac source feeds only Fundamental sinusoidal active component of unity power-factor current. Since this APF system is connected in shunt with load, it improves the system efficiency because it does not process the active power delivered to the load

3.1 Control Scheme

Fig. 3 shows the block diagram of an overall control scheme for the APF system. DC bus voltage and supply voltage and current are sensed to control the APE. AC source supplies fundamental active power component of load current and a fundamental component of a current to maintain average dc bus voltage to a constant value. The later component of source current is to supply losses in VSI such as switching loss, capacitor leakage current etc. in steady state and to recover stored energy on the dc bus capacitor during dynamic conditions such as addition or removal of the loads

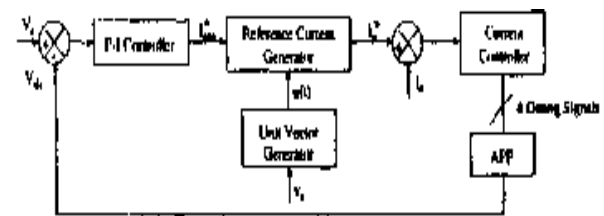

Figure 3 : Control Scheme of the APF

The sensed dc bus voltage of the APF along with its reference value are processed in the P-I voltage controller. The truncated output of the P-I controller is taken as peak of source current. A unit vector in phase with the source voltage is derived using its sensed value. The peak source current is multiplied with the unit vector to generate a reference sinusoidal unity power factor source current. The reference

source current and sensed source current are processed in hysteresis carrier less PWM current controller to derive gating signals for the MOSFETs of the APF. In response to these gating pulses, the APF impresses a PWM voltage to flow a current through filter inductor to meet the harmonic and reactive components of the load current. Since all the quantities such as dc bus voltage etc. are symmetric and periodic corresponding to the half cycle of the ac source. A corrective action is taken in each half cycle of the ac source resulting in fast dynamic response of the APF .

4. PERFORMANCE METRICS

Fig. 4 shows performance of APF system with non-Linear rectifier load. Load draws discontinuous peaky current from ac' bus. APF feeds harmonic and

reactive power components of load "current. AC source feeds only fundamental active power component of load current resulting in source current exactly in phase with source voltage. Source current remains sinusoidal during transient conditions and attains new steady state value without any overshoot and oscillation. A drop and a rise is observed in dc bus voltage at application and removal of additional load. However, during steady state the P-I voltage controller maintains a constant average voltage at the dc bus of the AF. Harmonic spectrum of load and supply currents at 15 A and 30 A peak values of load current is shown in Fig. 7 for rectifier type non-linear load. It may be observed that the harmonics are eliminated from source current. The THD in supply current is reduced to 4.67 from 83.92 % of the load current (15 A peak)

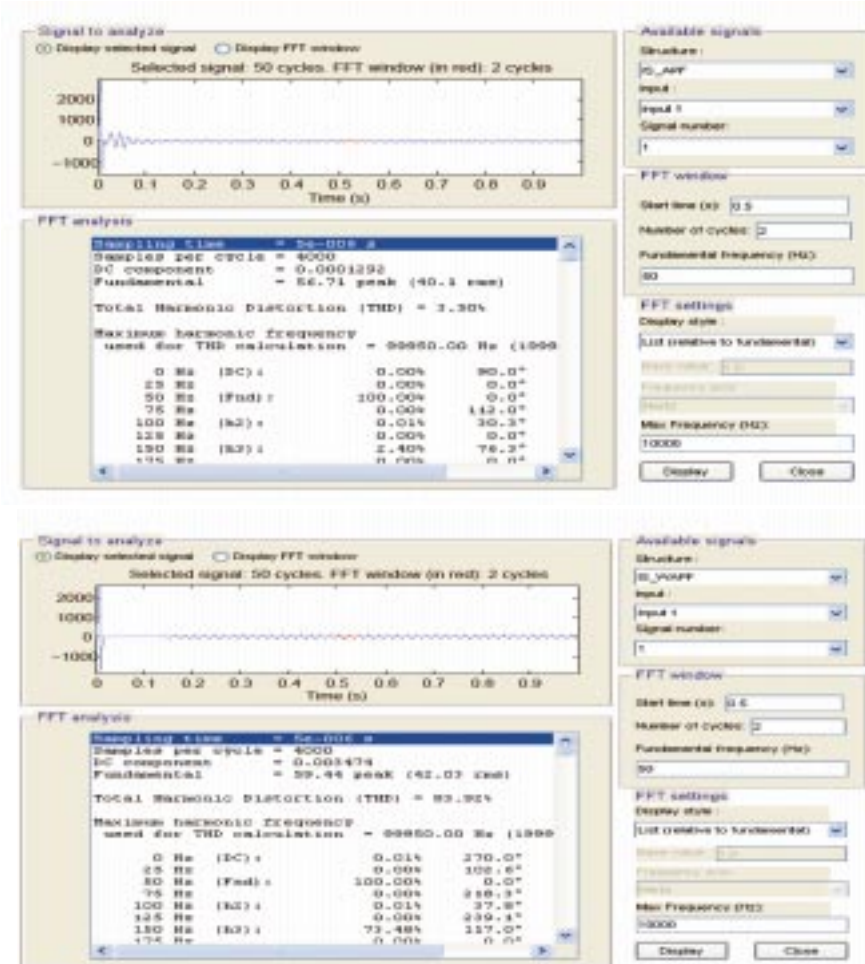

Figure 4 : Performance of the APF System under Non-linear

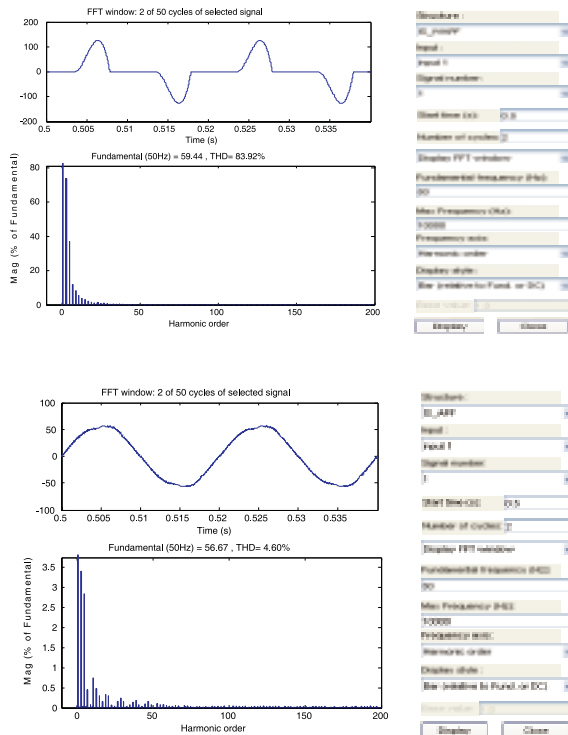

Figure 5 : Harmonic Spectrum with Nonlinear Rectifier Fed Load

5. RESULTS AND DISCUSSIONS

It is also noted from these waveforms that the power factor Decreases with decrease in load under duty ratio control. This is due to the fact that the power factor depends on ratio of switching frequency to resonant frequency. The APF eliminates harmonic components effectively and is able to compensate the reactive power

6. CONCLUSIONS & FUTURE WORK

In this paper we present the harmonic reduction system using active filter to reduce total harmonic distortion value by the computer which work with microcontroller and active harmonic filter. The harmonic reduction system program PWM and control active harmonic filter by analyze signal in system .The computer shows electric signal ,harmonic analysis ,function direct and automatic filter control. The results present ability of the harmonics reduction that increase the Efficiency of

electric system and can improve in the real system. A simple P-I controller based APF has been found effective to provide reactive power and harmonic compensation for the variety of loads. An excellent performance of APF system has been observed as a universal power-factor controller and an ideal reactive power compensator. APF is able to reduce the harmonics well below 5 % in all the cases of extremely reactive and harmonic polluted loads. APF has maintained sinusoidal supply current in phase with the supply voltage resulting in unity power-factor of the supply both in steady state and transient conditions

This PWM inverter also can be modified to study voltage sag, voltage swell, interruption, voltage transients, voltage fluctuation, voltage (light) flicker, voltage imbalance, over voltage, under voltage and also other harmonics performance parameters

7. REFERENCES

1. Tain-Syh Luor; "Influence of load characteristics on the applications of passive and active harmonic filters" Harmonics and Quality of Power, 2000. Proceedings. Ninth International Conference on, Volume: 1, 1-4 Oct. 2000 PP. 128 -133 vol.1.
2. P. Enjeti, P. D. Ziozas, and J. F. Lindsay, "Programmed PWM techniques to eliminate harmonics: A critical evaluation," IEEE Trans. Ind.Applicat., vol. 26, PP. 302–316, Mar. 1990.
3. Dariusz Czarkowski, Member; David V. Chudnovsky; Gregory V. Chudnovsky; and Ivan W. Selesnick "Solving the Optimal PWM Problem for Single-Phase Inverters" IEEE TRANSACTIONS ON CIRCUITS AND SYSTEMS-I: FUNDAMENTAL THEORY AND APPLICATIONS, VOL. 49, NO. 4, APRIL 2002.
4. Chen, Z.; Blaabjerg, F.; Pedersen, J.K.; "A study of parallel operations of active and passive filters" Power Electronics Specialists Conference,

2002. pesc 02. 2002 IEEE 33rd Annual , Volume:
2 , 23-27 June 2002 PP.1021 -1026 vol.2.

5. Wilson E. Kazibwe, Musoke H. Sendaula. Electric Power Quality Control Techniques. New York :Van Nosteand Reinhold,1993.
6. E.O. Brigham, "The Fast Fourier transform", Prentice- Hall,1974.
7. L.H. Thomas, "Using A Computer to Solve Problems in Physics, Application of digital Computer ," Boston. Mass. :Ginn,1963.
8. Acha, Enrique "Power system harmonics: Computer modeling and analysis" Chichester : John Wielely & Sons, c2001.
9. B. Sing, K. A. Haddad, A Chandra, "Universal Active Power Filter for single-phase reactive power and harmonic compensation," International conference on IEEE Power Quality, PP. 81 -87, 1998.

■